

Flex Kupplungen / Flex couplings

FN, K-MM

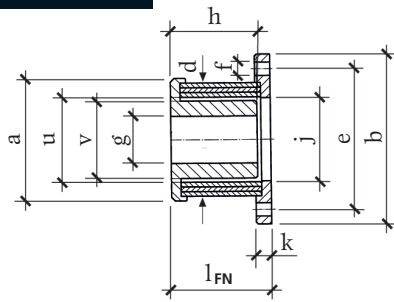

FN

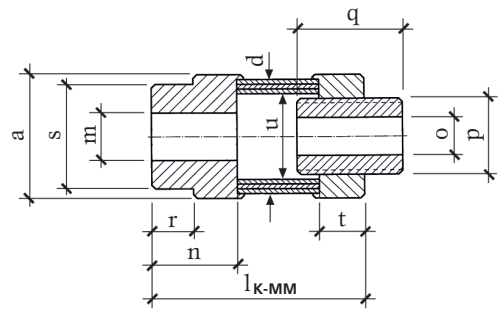

K-MM

Geometrische Daten / Dimensions

			20	25	35	45	55	
FN	a	mm	50	65	85	105	125	
	b		75	90	120	150	180	
	l _{FN}		44	52	66	86	110	
	d	mm	45	60	80	100	120	
	e		62	74.5	101.5	130	155.5	
	f		6 x Ø 5.8	4 x Ø 7	8 x Ø 7	8 x Ø 9.5	8 x Ø 11.5	
	g	vorgebohrt / Pilot bored max. mit Nut / max. with keyway	mm	9	14	23	28	33
h			20	30	42	55	65	
j ^{H7}		mm	32	44	60	75	88	
k			8	8	11	12	15	
v			30	41	55	72	84	
Art.-Nr. für vorgebohrte Ausführung / part no of pilot bored design			099400	099411	099431	099451	099471	
K-MM	a	mm	50	65	85	105	125	
	d		45	60	80	100	120	
	l _{K-MM}		85	110	145	185	225	
	m	vorgebohrt / Pilot bored max. mit Nut / max. with keyway	mm	9	15	19	29	41
	n			25	35	45	60	75
	o	max. mit Nut / max. with keyway	mm	35	45	60	75	90
	p	max. mit Nut / max. with keyway	mm	16	25	35	45	55
q	Vielkeilprofil / Spline (DIN 5462)		6 x 26 x 30	8 x 36 x 40	8 x 52 x 58	8 x 62 x 68	10 x 72 x 78	
r		mm	40	55	70	90	105	
s			17	21.5	33	38	43	
t			33	45	61	76	90	
u								
Art.-Nr. für vorgebohrte Ausführung ohne Schiebenabe part no bored design without splined shaft			099501	099511	099521	099531	099541	
Art.-Nr. für Schiebenabe / part no for splined shaft			099504	099514	099524	099534	099544	

Technische Daten / Specifications

Nennbohrung in mm = Grösse / Nominal bore in mm = size			20	25	35	45	55	
Nenn Drehmoment / Nominal torque	M _N	Nm	75	150	300	600	900	
Maximaldrehzahl / Max. speed	n _{max}	min ⁻¹	7000	6000	3000	1500	1500	
Nachgiebigkeit winklig / Angular misalignment	ΔW _w	°	2	2	2	2	2	
Nachgiebigkeit radial / Radial misalignment	ΔW _r	mm	0.4	0.5	0.7	0.9	1.1	
Nachgiebigkeit axial (Zug) / Axial misalignment (tension)	ΔW _a	mm	0.6	1.0	1.25	1.65	2	
Verdrehwinkel bei M _N / Angle of twist at M _N	φ _N ±25 %	°	1.5	2.5	2.5	3	3.5	
Massenträgheitsmoment (bei max. Bohrungen) Inertia (max. bore)	FN	J	kgm ²	2.98	7.74	31.5	93.8	245
	K-MM	J	·10 ⁻⁴	2.72	10.7	42.6	124	294
Masse (bei max. Bohrungen) Weight (max. bore)	FN	m	kg	0.55	0.96	2.15	4.1	7.6
	K-MM	m	kg	0.79	1.73	4	7.3	12